



Compressor Failures - The only driver for improvements?

Christian Hold, 11th EFRC Conference 2018 - Madrid

Constant stream of innovations required

Products can never be too reliable & efficient

HOERBIGER
because performance counts

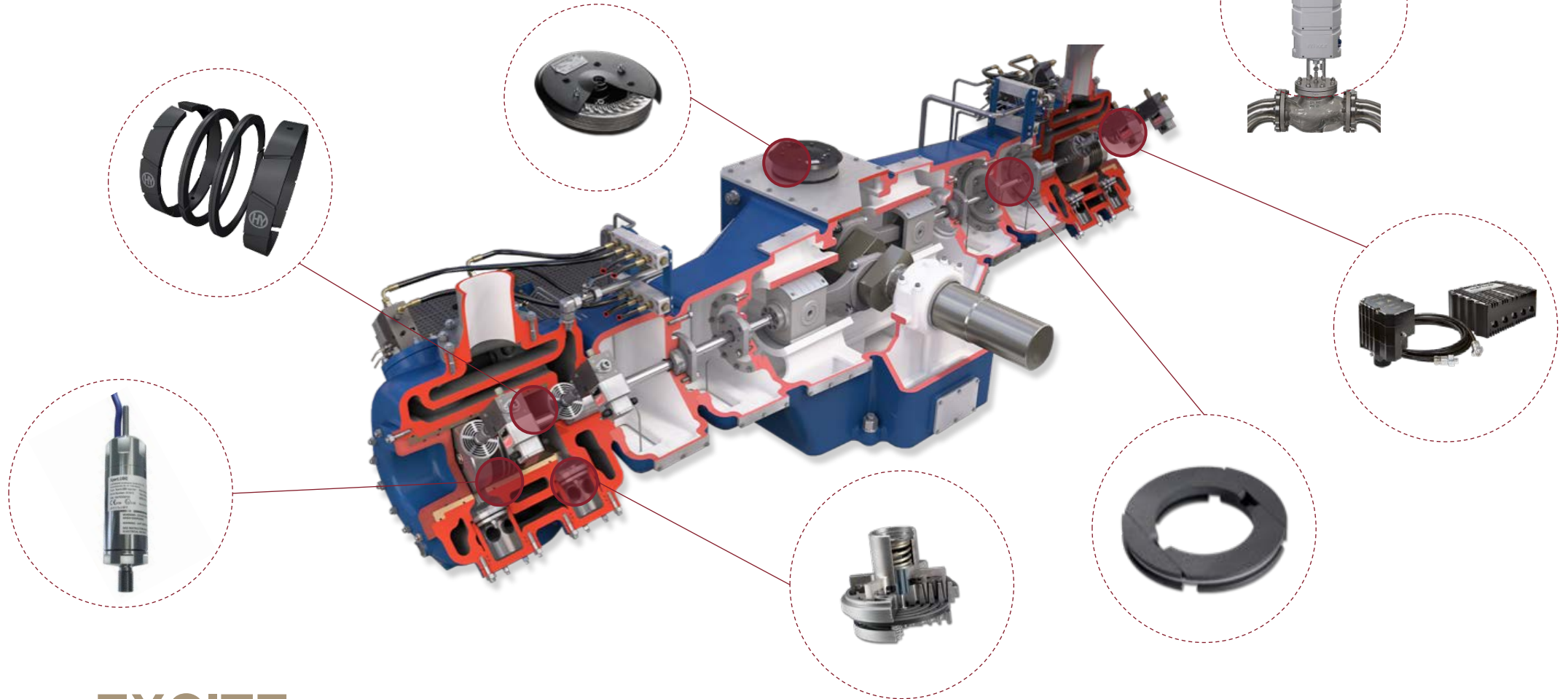

EXCITE

THE HOERBIGER PIONEER CLASS – for critical & challenging applications

EXCITE

THE HOERBIGER PIONEER CLASS



Managing does not imply doing it alone.
Rather, it means knowing whom to entrust
with important tasks.

EXPERIENCE

THE HOERBIGER ADVANCED CLASS

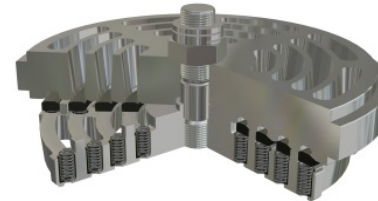

Production processes are networks.
Success requires that people and machines
work together in unison.

HOERBIGER
because performance counts

R&P innovation path of HOERBIGER

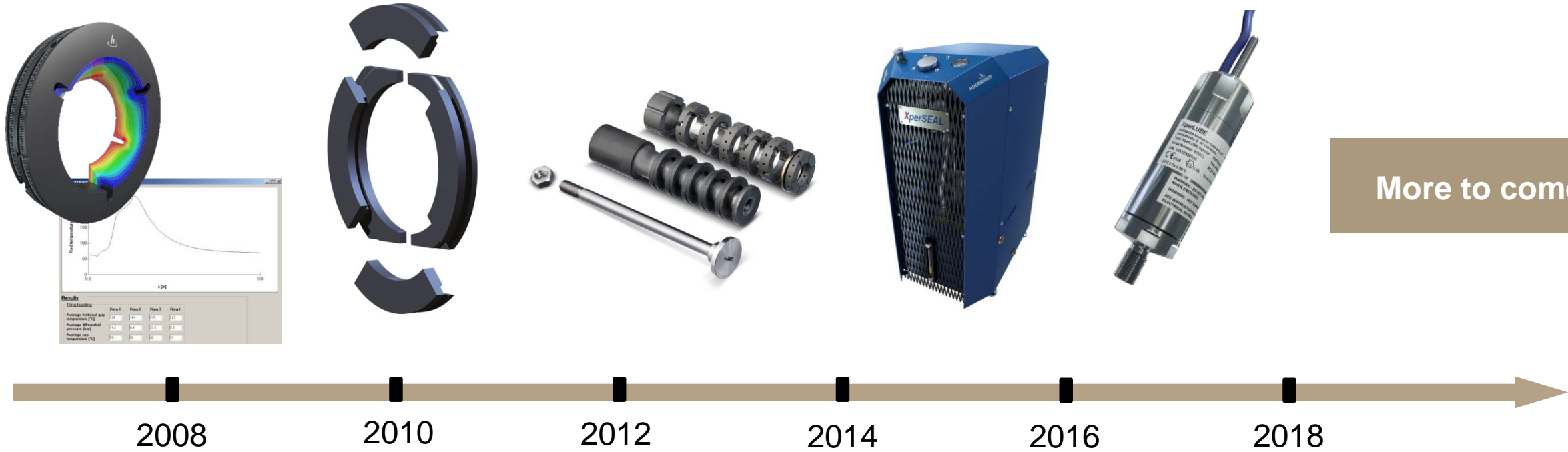

See the paper of Ralf Krich on Thursday, 17:35

**Non-lube operation – Do it right if necessary
A practical guideline and examples**

See the paper of Andreas Kaufmann on Friday, 15:10

**New insight into the wear of packing rings
Model, calculation, experiment**

Digitalisation – eRecip™ platform

Lean compressor solution sizing with reliability and efficiency index

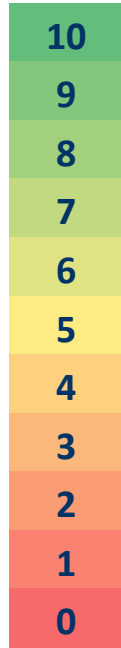

< 6.4
Compressor design
with traditional technologies

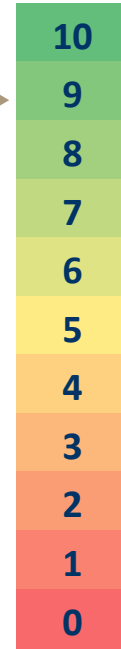
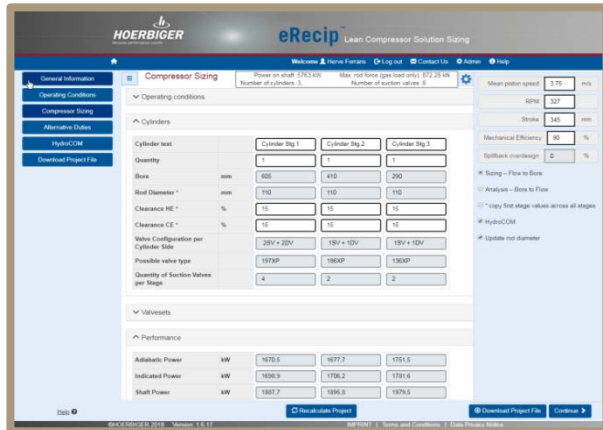
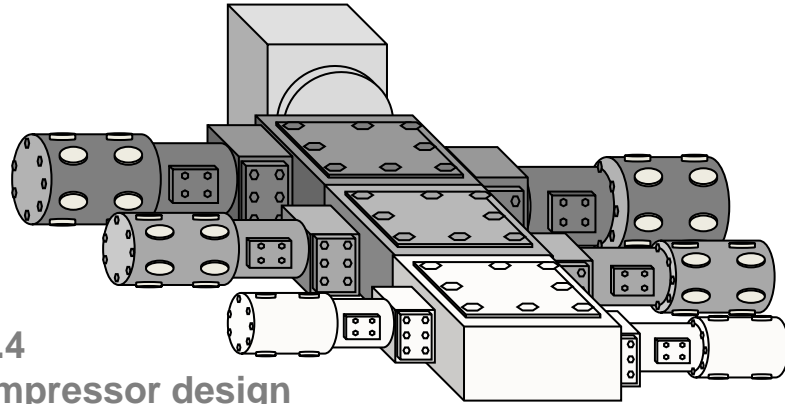

New compressor design
with advanced technologies
< 9.0

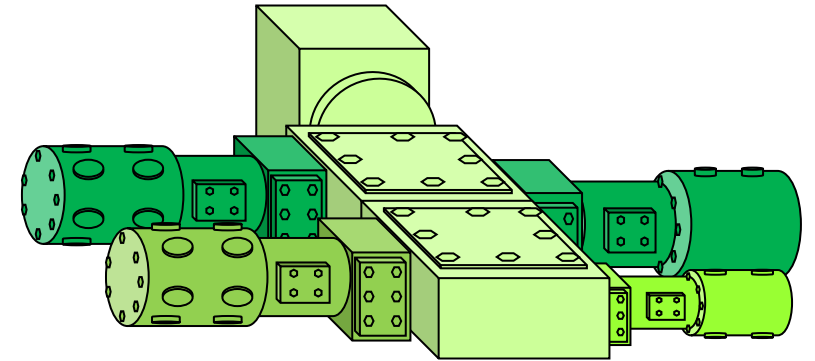

Objective: sustainable

- High reliability
- Improved efficiency
- Lower total cost ownership

→ www.erecip.com



HOERBIGER

See you at the booth!