



EUROPEAN FORUM  
for RECIPROCATING  
COMPRESSORS

## Exhibition Manual

**Date** September 13-14, 2018

**Website** For updated information about the conference please visit <https://recip.org/sponsorship-programme/>

**Organizer** European Forum for Reciprocating Compressors (EFRC)

**Contact for registration** Mrs. Michèle Infanger  
Marketing & Communications Coordinator  
c/o Burckhardt Compression AG  
Im Link 5, P.O. Box 3352  
CH-8404 Winterthur, Switzerland  
Tel. +41 52 262 57 77  
Email: [efrc@burckhardtcompression.com](mailto:efrc@burckhardtcompression.com)

**Stand builder** Mrs. Laura García  
Servis Group  
Email: [exhibitorservices@servisgroup.es](mailto:exhibitorservices@servisgroup.es)  
Phone: +34 93 423 31 07

**Conference venue** The exhibition area will be located in the floor PC (first floor) of Hotel NH Collection Madrid Eurobuilding, on the same floor as the EFRC main conference rooms.

**HOTEL NH COLLECTION MADRID EUROBUILDING**

Calle de Padre Damián, 23, 28036 Madrid (Spain)

For further information about the venue, including how to travel to the venue, please visit <https://www.nh-collection.com>

Coffee break will take place in the exhibition area allowing for maximum interaction with conference delegates.

**How to get there (Loading / Unloading)** The access of goods to the different areas of the Hotel NH Collection Madrid Eurobuilding is always through the loading dock located in the José Lázaro Galdiano street s/n Madrid.

**Car Park** There is a car park located in front of the Hotel NH Collection Madrid Eurobuilding. The maximum height is 1.90 meters.

**EXHIBITION**



## Participation Conditions

### 1. Booth design

Booths have different sizes (see on the exhibition floor plan). A basic shell scheme for every exhibitor will be provided and is mandatory.

Additional services can be ordered from the local stand builder Servis Group.

**IMPORTANT:** Please order booth material **AFTER** receiving the order confirmation of your booth.

### 2. Exhibit space includes

Each exhibit space includes:

- Booth area, shell scheme with back and side walls, fascia board with company name incl. max. 20 letters (no logo), 1 waste bin, 2 spotlights, each 120 Watt, standard carpet (grey) and one 230 VAC / 2000W mains supply per booth incl. Socket with 3 plugs
- Exhibitors' list

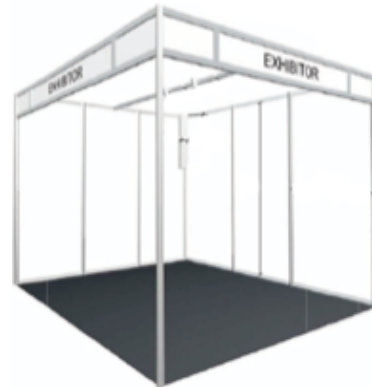

### 3. Order form

Booth furniture and additional materials such as displays, etc. can be directly ordered [here](#)

*Please click on the flag that you will find at the top-right corner to select English*

### 4. Exhibition fee

The booth area fee for all areas is: EUR 1,800 excl. VAT for EFRC members and EUR 2,200 excl. VAT for Non-EFRC members incl. the mandatory basic shell scheme booth.

**IMPORTANT:** Costs for additional services of the stand builder are NOT included in this fee. Any such additional services have to be ordered directly between the exhibitor and Servis Group.

Booth personnel have to be registered separately for the EFRC Conference.

### 5. Payment conditions (for exhibition space)

**PAYMENT BY INVOICE:** Provide the appropriate information on the exhibition order form. The invoice will be sent by our partner Kuoni Congress.

### 6. Shipment of booth material space

Booth material can be shipped to arrive earliest on September 12, 2018 (in the morning), prior to the EFRC Conference. It has to be well marked with EFRC 2018 and can be sent to the Conference Location. The pick-up for return of booth material has to take place on September 14, 2018 after the conference and has to be organized by the tenant. Additional cost caused by late pick-up will be invoiced to the exhibitor. Booth material has to be packed properly, marked well with the company's address and labelled with the shipping documents.

# 11th EFRC Conference September 13 and 14, 2018 - Madrid, Spain



## 7. Set up and dismantling schedule (provisional)

Set up will take place on Wednesday, 12th September from 12:00 to 19:00 hrs.  
All stands must be complete and all materials and tools removed from the exhibition hall by 19:00 hrs so that a full clean of the stands and public walkways can take place.  
Dismantling will take place on Friday, September 14 immediately AFTER the end of the conference from 17:00 to 20:00h

All stand materials need to be removed from the exhibition hall by 20:00 on Friday September 14. Neither the organisers nor the venue will take responsibility for any items left in the exhibition hall after this time. Any items that need to be collected by courier should be labelled up with the appropriate delivery address and left with RESA EXPO LOGISTICS, the official forwarding agent. All items are left at owners' own risk.

All exhibition stands must be identified by a stand number or stand name, which is identical with that on the exhibition floorplan.

## 8. Lift measures

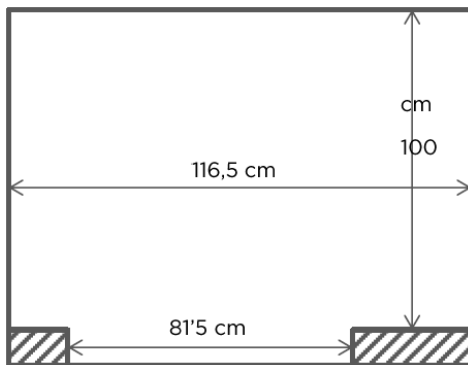

## 9. Exhibit opening hours

The exhibit will be opened at the following times:  
Wednesday, September 13 from 8.00 to 19.00  
Thursday, September 14 from 9.00 to 17.00

## 10. Further regulations

Exhibits of the exhibitors are allowed. Water and compressed air supply cannot be provided. Please take this and the maximum power available into consideration when selecting your exhibits.

Due to weight restrictions in the conference location no heavy loads or big machines are permitted (max 250 kg per m<sup>2</sup>). Use of forklift trucks or pallet trucks is prohibited.

For safety reasons Hotel NH Collection Madrid Eurobuilding prohibits the use of highly flammable materials or liquids (for example polystyrene).

Hotel NH Collection Madrid Eurobuilding and EFRC do not accept any responsibility for damages caused by third parties or for any loss of property in the exhibition booths or in the storage area.

Booth tenants are responsible and liable for any damage to the conference building caused by booth tenants or their representatives or companies contracted by the booth tenants.

It is not allowed to cause any high level noise in the exhibition area, e.g. by machinery or means of presentation.

EFRC as the organizer reserves the right to make the selection of exhibitors and final booth allocation and reserves the right to carry out alterations to the floor plan, if needed.

EXHIBITION

# 11th EFRC Conference September 13 and 14, 2018 - Madrid, Spain



## 11. Catering

The Hotel NH Collection Madrid Eurobuilding is the sole purveyor of food and beverages at the venue and, as such, has the sole right to provide food and drink for consumption on stands and in offices.

## 12. Security rules

Exhibitors must wear accreditation badges at all times.

The exhibitors agree to adopt all control and safety measures established by the Municipal Government of Madrid or by the management of the Hotel NH Collection Madrid Eurobuilding.

The exhibitor formally declares that their staff are insured and covered by social security and other labour and tax obligations foreseen in the legislation in force, absolving the Hotel NH Collection Madrid Eurobuilding from any possible claim or involvement in these matters

The exhibitors are responsible for the damage caused to the rented installations by all staff under their orders.

Smoking is strictly forbidden in all facilities of the Hotel NH Collection Madrid Eurobuilding.

## 13. Electricity rules

The Hotel NH Collection Madrid Eurobuilding reserves the right to limit the power supply in the interests of general safety to prevent overloading or for the protection of the cables and other installations of the venue.

As the Hotel NH Collection Madrid Eurobuilding is fully dependent on the Electricity Board for its power, it can in no way be held responsible for inconsistencies in the supply caused by accidents, power shortages or power cuts, beyond its control.

The Hotel NH Collection Madrid Eurobuilding is not responsible for providing any kind of material needed by exhibitors that functions on a direct current (DC) or any other kind of current that differs from the general supply, that being 220V or 380V .

Electrical Connections: Connections will be made from the high safety power outlet deemed most appropriate by the venue's onsite technician, to ensure the best use of the electrical network.

Safety measures: The location of any fire-fighting material such as fire hoses and fire alarms, as well as access to emergency exits, must be strictly respected at all times, even when these fall within a contracted space or stand area. Access to service areas, cables, socket outlets and fuse boxes must also be respected at all times.

## 14. Cleaning services

Each exhibitor agrees to keep their stand and its environment clean.

The exhibition floor and public areas will be cleaned daily and any waste removed.

The daily cleaning of the stands is not included in the cost of the stand and for those who require it has to be requested directly to the Conference secretariat before the beginning of the conference.

## 15. Exhibition hall

The placement of materials in the space of other exhibitors and common spaces is not allowed. These must always remain free for the circulation of people and materials.

Warehouse, mailing, shipping of stand material and logistics

Owing to the complexity of the loading & unloading and with the only purpose of minimizing the risks, especially during the events, we encourage working with a logistics company which can be in charge of the operations.

**EXHIBITION**

## 11th EFRC Conference September 13 and 14, 2018 - Madrid, Spain



EUROPEAN FORUM  
for RECIPROCATING  
COMPRESSORS

The Hotel NH Collection Madrid Eurobuilding does not have a warehouse, so we recommend contracting the services of RESA EXPO LOGISTICS for the storage, delivery and the pickup of exhibition material.

The Hotel NH Collection Madrid Eurobuilding and the organization reject any liability for all the material sent and the material which has not arrived or cannot be found due to incorrect addresses.

All stand materials should be sent to Hotel NH Collection Madrid Eurobuilding on Wednesday, September 12 from 09h00 to 16h00. Please be aware that the venue will not accept ANY packages prior to September 12, 2018.

---

**Address** Hotel NH Collection Madrid Eurobuilding  
Calle de Padre Damián, 23  
28036 Madrid (Spain)  
Ref. 11th EFRC Conference  
Att. Mrs. Naiara Campo  
Indicate the stand number and company name

---

Before shipping any items to your stand please make sure you get in touch with the official handling company, RESA EXPO LOGISTICS.

They will be happy to solve your doubts and offer their services for reception and delivery or unloading to stand of your materials.

Please note that the venue does not receive customs clear or store incoming shipments. If you intend to ship goods directly to your stand, you need to be there in order to sign off the delivery note of your transport company. Please see contact details below.

### **RESA EXPO LOGISTICS**

Email: [operations@resaexpo.com](mailto:operations@resaexpo.com)  
Tel + 34 91 669 40 79

**EXHIBITION**

**11th EFRC Conference September 13 and 14,  
2018 - Madrid, Spain**



**EFRC**  
EUROPEAN FORUM  
for RECIPROCATING  
COMPRESSORS

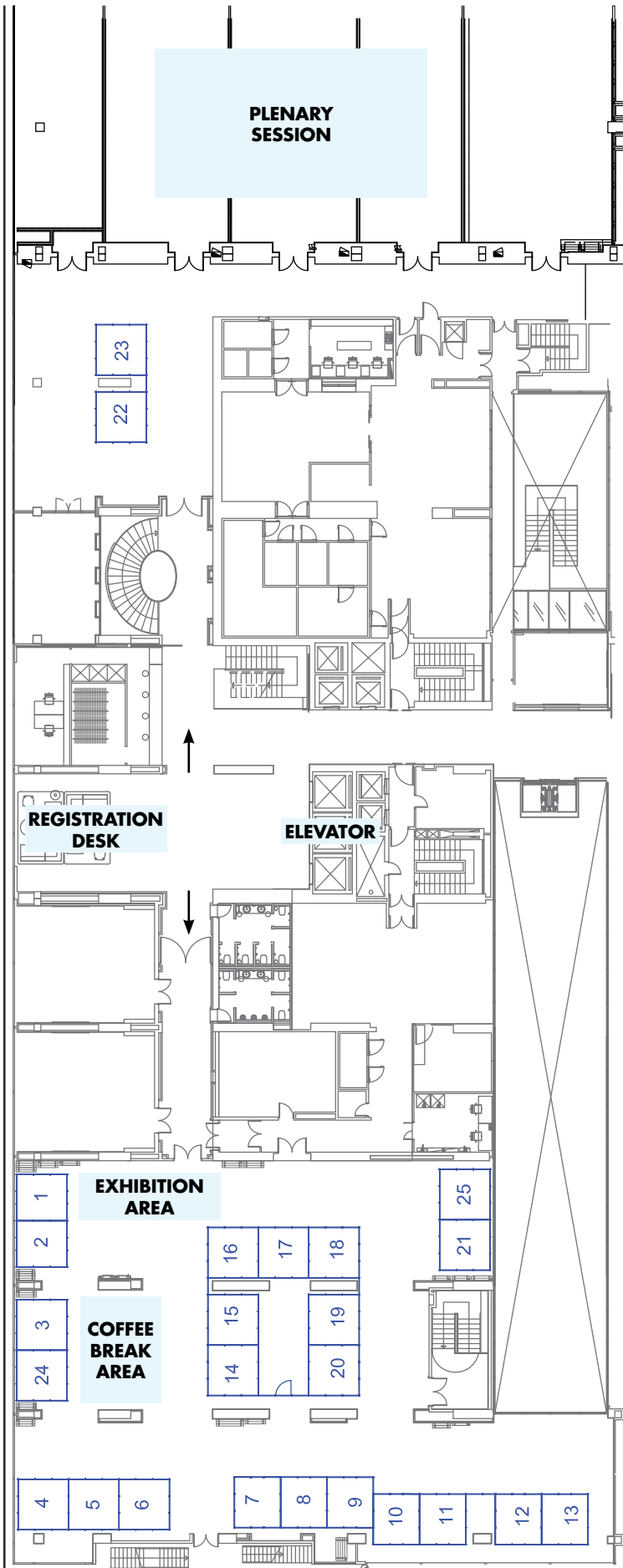

**SELECTED STANDS**

- 1.** Ariel Corporation
- 2.** EGC Critical Components
- 3.** TNO
- 4.** ANTWERP LION OIL WORKS NV
- 5.** COOK Compression Ltd.
- 6.** HOERBIGER Ventilwerke GmbH & Co. KG
- 7.** BORSIG ZM Compression GmbH
- 8.** Sauer Compressors
- 9.** Compressor Products International
- 10.** Dynaflo Research Group
- 11.** Windrock Inc.
- 12.** WEG
- 13.** Baker Hughes
- 14.** Burckhardt Compression AG
- 15.** NEUMAN & ESSER Deutschland GmbH & Co. KG
- 16.** DOTT.ING.MARIO COZZANI S.R.L.
- 17.** ARIZAGA, BASTARRICA Y CIA, SA
- 18.** PROGNOT Systems GmbH
- 19.** Howden
- 20.** STASSKOL GmbH
- 21.** KÖTTER Consulting Engineers GmbH & Co. KG
- 22.** CompressorTech 2
- 23.** KRMEA
- 24.** Siemens
- 25.** Chockfast Distributor Group

**2,93 x 2,93 m**

Stands 14 - 15 - 16 - 17  
18 - 19 - 20 - 22 - 23

**3 x 2,68 m**

Stands 1 - 2 - 3 - 7 - 8 - 9  
10 - 11 - 12 - 13 - 21  
24 - 25

**3 x 2,93 m**

Stands 4 - 5 - 6

**EXHIBITION**